

Family Letter

Dear Parent or Guardian:

We use mathematical skills in many of the things that we do. One of the goals of this class is to show students how the information they are learning in the classroom is relevant to the real world. For example, understanding perimeter, area, and volume is useful in such diverse fields as geography, navigation, sports, and architecture.

In **Chapter 10, Measurement: Perimeter, Area, and Volume**, your child will learn how to find the perimeter of polygons and circumference of circles. Your child will also learn to find the areas of parallelograms and triangles. Your child will also explore three-dimensional figures by finding the volume and surface area of rectangular prisms, using a net to build a cube, and by making a model. Finally, your child will learn to select appropriate formulas and units. In the study of this chapter, your child will complete a variety of daily classroom assignments and activities and possibly produce a chapter project.

By signing this letter and returning it with your child, you agree to encourage your child by getting involved. Enclosed is an activity that you can do with your child that practices how the math we will be learning in Chapter 10 might be tested. You may also wish to log on to **www.msmath1.com** for self-check quizzes and other study help. If you have any questions or comments, feel free to contact me at school.

Sincerely,

Signature of Parent or Guardian _____ Date _____

10**Family Activity****State Test Practice**

Fold the page along the dashed line. Work each problem on another piece of paper. Then unfold the page to check your work.

1. Emilio knows that his car tire has a diameter of 0.5 m. He wants to know how far the wheel will go in three complete spins. How can he find this?

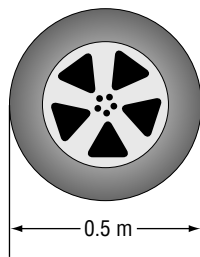

- A** He can multiply the diameter by π and then by 3.
B He can divide the diameter by π and then multiply by 3.
C He can multiply the diameter by 3.
D He cannot determine how far the wheel will go in 3 turns.

Fold here.

Solution

1. *Hint: The circumference of a circle is the distance around the circle. The formula for circumference is πd or $2\pi r$.*

Each point around the circle will touch the ground once in a complete spin, so the circumference of the circle is the distance the tire will go in one spin. The circumference can be found by multiplying the diameter by pi (π), so for each spin, the tire will travel πd meters. For three spins, the circumference should be multiplied by three, or $3\pi d$. The option that describes this process is Option A, or the diameter multiplied by pi (π) and then multiplied by 3.

The answer is **A**.

2. Find the volume of the following rectangular prism.

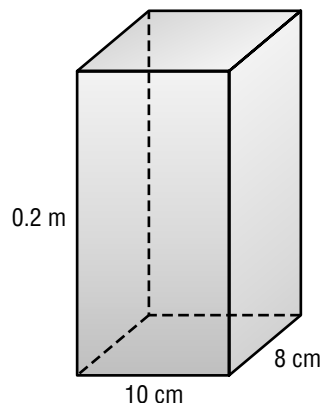

- A** $V = 1,600 \text{ cm}^2$
B $V = 1,600 \text{ cm}^3$
C $V = 16 \text{ cm}^2$
D $V = 16 \text{ cm}^3$

Solution

2. *Hint: Before you calculate the volume, make sure that all of the dimensions are converted to the same units.*

The height should be converted to centimeters so that the units are consistent. There are 100 cm in a meter, so 0.2 m is equivalent to 20 cm.

The volume of a rectangular prism can be calculated using this formula:

$$V = \ell \times w \times h.$$

In this case the volume is:

$$V = 8 \text{ cm} \times 10 \text{ cm} \times 20 \text{ cm} = 1600 \text{ cm}^3$$

Notice that the units are cubed, because you are multiplying $\text{cm} \times \text{cm} \times \text{cm} = \text{cm}^3$. The units for volume will always be cubic.

The answer is **B**.